



TISSEEL (Fibrin Sealant)

HIGHLIGHTS OF PRESCRIBING INFORMATION

These highlights do not include all the information needed to use TISSEEL safely and effectively. See full prescribing information for TISSEEL.

TISSEEL (Fibrin Sealant)

For Topical Use Only

Frozen solution and lyophilized powder for solution for topical application

Initial U.S. Approval: 1998

----- **RECENT MAJOR CHANGES** -----
 Indications and Usage (1) 01/2012

----- **INDICATIONS AND USAGE** -----

- **Hemostasis:** TISSEEL is a fibrin sealant indicated for use as an adjunct to hemostasis in patients undergoing surgery when control of bleeding by conventional surgical techniques (such as suture, ligature, and cautery) is ineffective or impractical. TISSEEL is effective in heparinized patients.(1.1)
- **Sealing:** TISSEEL is a fibrin sealant indicated as an adjunct to standard surgical techniques (such as suture and ligature) to prevent leakage from colonic anastomoses following the reversal of temporary colostomies (1.2)

----- **DOSAGE AND ADMINISTRATION** -----

For Topical Use Only. Do Not Inject (2)

- Apply TISSEEL as a thin layer by dripping or spraying using cannula or spray set (2.3, 5.2)
- Ensure that the amount of TISSEEL to be applied is sufficient to entirely cover the intended application area (2.3)

----- **DOSAGE FORMS AND STRENGTHS** -----

TISSEEL Kit (Freeze-Dried) is supplied as 2 mL, 4 mL and 10 mL (total volume) pack sizes with and without the DUPLOJECT System (3)

TISSEEL Pre-filled Syringe (Frozen) is supplied as 2 mL, 4 mL and 10 mL (total volume) pack sizes with the DUO Set (3)

----- **CONTRAINDICATIONS** -----

- Do not inject directly into the circulatory system or into highly vascularized tissue (4.1, 5.3)
- Do not use in individuals with a known hypersensitivity to aprotinin (4.2, 5.1, 6)
- Do not use for the treatment of severe or brisk arterial or venous bleeding (4.3)

----- **WARNINGS AND PRECAUTIONS** -----

- TISSEEL contains aprotinin, a protein known to be associated with anaphylactic reactions (4.2, 5.1, 6)
- Air or gas embolism has occurred when fibrin sealant was administered using pressurized gas. This may occur if a spray device is used at higher than recommended pressures and in close proximity to the surface of the tissue (5.2)
- TISSEEL is denatured when exposing to solutions containing alcohol, iodine or heavy metals (5.2)
- Apply only as a thin layer as excess clot thickness may negatively interfere with wound healing (2, 5.2)
- Exercise caution to minimize the risk of intravascular application when using TISSEEL in surgery (4.1, 5.3, 6.2)
- Safety has not been evaluated in neurosurgical procedures (5.4)
- TISSEEL is made from pooled human plasma which may contain infectious agents (5.5)

----- **ADVERSE REACTIONS** -----

Hypersensitivity or allergic/anaphylactoid reactions have occurred (6)

To report SUSPECTED ADVERSE REACTIONS, contact Baxter Healthcare Corporation at 1-866-888-2472 or FDA at 1-800-FDA-1088 or www.fda.gov/medwatch.

----- **DRUG INTERACTIONS** -----

Oxidized cellulose-containing preparations may reduce the efficacy of TISSEEL and should not be used as carrier materials (7)

----- **USE IN SEPCIFIC POPULATIONS** -----

Pregnancy: No human or animal data. Use only if clearly needed (8.1)

See 17 for PATIENT COUNSELING INFORMATION

Revised: 01/2012

FULL PRESCRIBING INFORMATION: CONTENTS *

1 INDICATIONS AND USAGE

- 1.1 Hemostasis
- 1.2 Sealing

2 DOSAGE AND ADMINISTRATION

- 2.1 Preparation of TISSEEL Kit (Freeze-Dried)
- 2.2 Preparation of TISSEEL Pre-Filled Syringe (Frozen)
- 2.3 Method of Application

3 DOSAGE FORMS AND STRENGTHS

4 CONTRAINDICATIONS

- 4.1 Intravascular Application
- 4.2 Aprotinin Hypersensitivity
- 4.3 Severe or Brisk Bleeding

5 WARNINGS AND PRECAUTIONS

- 5.1 Hypersensitivity/Allergic/Anaphylactic Reactions
- 5.2 Application Precautions
- 5.3 Use in Surgery
- 5.4 Use in Neurosurgical Procedures
- 5.5 Infection Risk from Human Plasma

6 ADVERSE REACTIONS

- 6.1 Clinical Trials Experience
- 6.2 Post Marketing Experience

7 DRUG INTERACTIONS

8 USE IN SPECIFIC POPULATIONS

- 8.1 Pregnancy
- 8.3 Nursing Mothers
- 8.4 Pediatric Use
- 8.5 Geriatric Use

11 DESCRIPTION

- 11.1 Viral Clearance

12 CLINICAL PHARMACOLOGY

- 12.1 Mechanism of Action
- 12.2 Pharmacodynamics
- 12.3 Pharmacokinetics

13 NONCLINICAL TOXICOLOGY

- 13.1 Carcinogenesis, Mutagenesis, Impairment of Fertility

14 CLINICAL STUDIES

- 14.1 Vascular Surgery
- 14.2 Cardiac Surgery
- 14.3 Cardiac Reoperations
- 14.4 Splenectomy
- 14.5 Colostomy Closure

16 HOW SUPPLIED/STORAGE AND HANDLING

17 PATIENT COUNSELING INFORMATION

1 INDICATIONS AND USAGE

- 1.1 **Hemostasis:** TISSEEL is a fibrin sealant indicated for use as an adjunct to hemostasis in patients undergoing surgery when control of bleeding by conventional surgical techniques (such as suture, ligature, and cautery) is ineffective or impractical. TISSEEL is effective in heparinized patients.
- 1.2 **Sealing:** TISSEEL is a fibrin sealant indicated as an adjunct to standard surgical techniques (such as suture and ligature) to prevent leakage from colonic anastomoses following the reversal of temporary colostomies.

2 DOSAGE AND ADMINISTRATION

FOR TOPICAL USE ONLY – DO NOT INJECT

Vials and pre-filled syringes are for single use only. Discard any unused product.

2.1 Preparation of TISSEEL Kit (Freeze-Dried)

DO NOT EXPOSE TO TEMPERATURES ABOVE 37°C

DO NOT MICROWAVE

DO NOT REFRIGERATE OR FREEZE AFTER RECONSTITUTION

Do not use iodine or heavy metal containing preparations such as betadine for disinfection of vial stoppers.

Allow alcohol-based disinfectants to evaporate before puncturing stopper.

Use separate syringes and transfer devices for reconstituting Sealer Protein and Thrombin solutions and for application to prevent clotting.

The product must be used within 4 hours after reconstitution.

Freeze-dried Sealer Protein Concentrate and Thrombin are reconstituted in Fibrinolysis Inhibitor Solution and Calcium Chloride Solution, respectively. The Sealer Protein Solution and Thrombin Solution are then combined using the DUPLOJECT Preparation and Application System, or an equivalent delivery device cleared by FDA for use with TISSEEL, to form the Fibrin Sealant.

Prewarming TISSEEL Kit with FIBRINOTHERM

See FIBRINOTHERM manual for complete operating instructions. If a FIBRINOTHERM device is not available, contact Baxter (1-800-423-2090) for assistance.

1. Place all four vials from the TISSEEL Kit into the prewarmed wells of the FIBRINOTHERM, using the appropriately sized adapter ring(s), and allow the vials to warm for up to 5 minutes (room temperature product will take less time).

Preparation of Sealer Protein Solution with FIBRINOTHERM

1. Remove the caps from the Sealer Protein Concentrate and the Fibrinolysis Inhibitor Solution vials.
2. Transfer the Fibrinolysis Inhibitor Solution into the vial containing the freeze-dried Sealer Protein Concentrate using the sterile reconstitution components (see directions provided with the device system for specific reconstitution instructions). Gently swirl the vial to ensure that the product is completely soaked.
3. Place the vial into the largest opening of the FIBRINOTHERM device with the appropriate adaptor. Switch on the stirrer and allow the vial contents to stir until all Sealer Protein Concentrate is dissolved. Reconstitution is complete when no undissolved particles are visible.

Notes:

- If the Sealer Protein Concentrate has not fully dissolved within 20 minutes discard the vial and prepare a fresh kit.
- Keep the Sealer Protein Solution at 37°C without stirring. Stir shortly before drawing up the solution to ensure homogeneity.

Preparation of Thrombin Solution with FIBRINOTHERM

To reconstitute the Thrombin (Human) with the Calcium Chloride Solution; follow steps 1–3 under **Preparation of Sealer Protein with FIBRINOTHERM** utilizing the Thrombin and Calcium Chloride vials.

Transferring to the Sterile Field

For transfer of the Sealer Protein and Thrombin Solutions to the sterile field, the circulating nurse should disinfect the tops of the vials with a germicidal solution and allow to dry. The scrub nurse should withdraw the sterile solutions while the circulating nurse holds the non-sterile vials. The solutions should be withdrawn slowly by firm constant aspiration to reduce the risk of large air bubbles.

2.2 Preparation of TISSEEL Pre-Filled Syringe (Frozen)

DO NOT EXPOSE TO TEMPERATURES ABOVE 37°C

DO NOT MICROWAVE

DO NOT REFRIGERATE OR RE-FREEZE

Do not use TISSEEL (frozen) until it is completely thawed and warmed (liquid consistency) to 33–37°C.

Do not remove the protective syringe cap until use.

Sterile Water Bath (Quick Thawing): Transfer inner pouch to the sterile field, remove pre-filled syringe from inner pouch and place directly into sterile water bath ensuring the syringe is completely immersed in the water. Maintain the product at 33–37°C until use. If the package is opened or warmed to 33–37°C, it must be used within 4 hours.

Non-Sterile Water Bath: Maintain the pre-filled syringe in pouches and place into a water bath outside the sterile field ensuring the pouches remain submerged. Remove from the water bath after thawing and warming, dry the external pouch and transfer inner pouch with pre-filled syringe onto the sterile field. Maintain the product at 33–37°C until use. If the package is opened or warmed to 33–37°C, it must be used within 4 hours.

Incubator: Maintain the pre-filled syringe in pouches and place into an incubator. Remove from the incubator after thawing and warming. Transfer inner pouch with pre-filled syringe onto the sterile field. Maintain the product at 33–37°C until use. If the package is opened or warmed to 33–37°C, it must be used within 4 hours.

Table 1: Approximate Water Bath or Incubator Thawing and Warming Times

Pack Size	Sterile Water Bath (Pouches Removed) 33–37°C	Non-Sterile Water Bath (In Pouches) 33–37°C	Incubator (In Pouches) 33–37°C
2 mL	5 minutes	30 minutes	40 minutes
4 mL	5 minutes	40 minutes	85 minutes
10 mL	12 minutes	80 minutes	105 minutes

Room Temperature Thawing: Unopened pouches may be stored for up to 48 hours at room temperature (15–25°C). Before use, warm the product to 33–37°C and apply immediately. The total thawing and warming time cannot exceed 48 hours.

Table 2: Approximate Room Temperature Thawing Times

Pack Size	Room Temperature (In Pouches) 15–25°C
2 mL	60 minutes
4 mL	110 minutes
10 mL	160 minutes

Table 3: Approximate Water Bath or Incubator Warming Times for Thawed Product

Pack Size	Sterile Water Bath (Pouches Removed) 33–37°C	Non-Sterile Water Bath (In Pouches) 33–37°C	Incubator (In Pouches) 33–37°C
2 mL	2 minutes	16 minutes	20 minutes
4 mL	2 minutes	21 minutes	43 minutes
10 mL	6 minutes	43 minutes	52 minutes

* Sections or subsections omitted from the full prescribing information are not listed.

2.3 Method of Application

Dry the site of application as much as possible.

Apply TISSEEL as a thin layer by dripping or spraying using a cannula or spray set. The treating physician will determine the amount of TISSEEL to be applied based on the surface to be covered. Ensure that the amount applied is sufficient to entirely cover the intended application area. The approximate surface areas covered by each package size of TISSEEL are listed in Table 4:

Table 4: Surface Area Coverage

Required package size of TISSEEL	Maximum coverage using spray	Maximum coverage using cannula
2 mL	100 cm ²	8 cm ²
4 mL	200 cm ²	16 cm ²
10 mL	500 cm ²	40 cm ²

Avoid application beyond the intended area. Allow at least 2 minutes after application to achieve sufficient polymerization. If repeat application is needed, dry the site as much as possible before reapplying. Reapply after removing residues from the prior application or before polymerization takes place since TISSEEL may not adhere firmly to a polymerized layer.

In cases where very small volumes (1–2 drops) are required, expel and discard the first several drops from the application cannula immediately before application to ensure administration of adequately mixed TISSEEL.

Exercise caution when applying TISSEEL using pressurized gas (see *Warnings and Precautions* (5.2)).

The product name, batch number and patient information should be recorded for traceability purposes.

TISSEEL Kit (Freeze-Dried)

Apply TISSEEL using the DUPLOJECT Fibrin Sealant Preparation and Application System or an equivalent delivery device (including open and minimally invasive spray devices) cleared by FDA for use with TISSEEL. Specific instructions for the use of TISSEEL in conjunction with each cleared delivery device are provided with the device.

TISSEEL Pre-filled Syringe (Frozen)

Apply pre-filled TISSEEL using the DUO Set accessory devices provided with the product or an equivalent delivery device (including open and minimally invasive spray devices) cleared by FDA for use with TISSEEL.

DUO Set Instructions (see Figure 1 below):

1. Insert plunger into syringe barrel.
 2. Firmly connect the two syringe nozzles to the joining piece (Y connector) and secure it by fastening the tether strap to the syringe.
 3. Fit an application cannula to the joining piece. Apply by depressing plunger.
- Note: Interruption of TISSEEL application causes clogging in the cannula. Replace the cannula immediately prior to resuming application. If the opening of the joining piece (Y connector) facing the cannula is clogged, use the spare joining piece provided in the package.

Figure 1
DUO SET

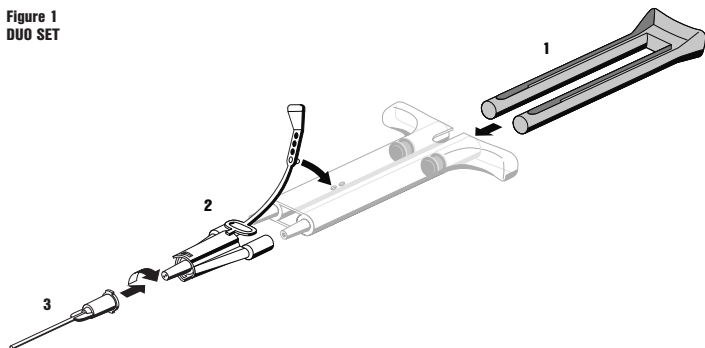

3 DOSAGE FORMS AND STRENGTHS

TISSEEL Kit (Freeze-Dried) is supplied as 2 mL, 4 mL and 10 mL (total volume) pack sizes with and without the DUPLOJECT System.

TISSEEL Pre-Filled Syringe (Frozen) is supplied as 2 mL, 4 mL and 10 mL (total volume) pack sizes with the DUO Set.

4 CONTRAINDICATIONS

4.1 Intravascular Application

Do not inject TISSEEL directly into the circulatory system or into highly vascularized tissue. Intravascular application of TISSEEL can lead to intravascular coagulation, may result in life-threatening thromboembolic events, and may increase the likelihood and severity of acute hypersensitivity reactions in susceptible patients (see *Warnings and Precautions* (5.3) and *Adverse Reactions* (6.2)).

4.2 Aprotinin Hypersensitivity

Do not use TISSEEL in individuals with a known hypersensitivity to aprotinin (see *Warnings and Precautions*, (5.1) and *Adverse Reactions* (6)).

4.3 Severe or Brisk Bleeding

Do not use TISSEEL for treatment of severe or brisk arterial or venous bleeding. In these situations, TISSEEL will be washed away in the flow of blood before hemostasis can be attained.

5 WARNINGS AND PRECAUTIONS

5.1 Hypersensitivity/Allergic/Anaphylactic Reactions

Hypersensitivity or allergic/anaphylactoid reactions may occur with the use of TISSEEL. Cases (<1/10,000) have been reported in post marketing experience with Baxter's fibrin sealant (see *Adverse Reactions* (6.2)). In specific cases, these reactions have progressed to severe anaphylaxis. Such reactions may especially be seen if TISSEEL is applied repeatedly over time or in the same setting, or if systemic aprotinin has been administered previously. Even if the first treatment was well tolerated, this may not exclude the occurrence of an allergic reaction after a subsequent administration of TISSEEL or systemic aprotinin. Observed symptoms of allergic anaphylactic reactions to TISSEEL have included: bradycardia, tachycardia, hypotension, flushing, bronchospasm, wheezing, dyspnea, nausea, urticaria, angioedema, pruritus, erythema and paresthesia. Such reactions may also occur in patients receiving TISSEEL for the first time.

Aprotinin is included in TISSEEL for its antifibrinolytic properties. Aprotinin, a protein, is known to be associated with anaphylactic reactions. Even in the case of strict local application of aprotinin, there is a risk of anaphylactic reactions to aprotinin, particularly in the case of previous exposure (see *Contraindications* (4.2)). TISSEEL does not contain any substances of bovine origin.

Discontinue administration of TISSEEL in the event of hypersensitivity reactions. Mild reactions can be managed with antihistamines. Severe hypotensive reactions require immediate intervention using current principles of shock therapy. Remove remaining product from the application site.

5.2 Application Precautions

Air or gas embolism has occurred when fibrin sealant was administered using pressurized gas. This may occur if a spray device is used at higher than recommended pressures and in close proximity to the tissue surface.

When applying TISSEEL using a spray device, be sure to use the pressure within the pressure range recommended by the spray device manufacturer. In the absence of a specific recommendation avoid using pressure above 20–25 psi. Do not spray closer than the distance recommended by the spray device manufacturer. In the absence of a specific recommendation avoid spraying closer than 10–15 cm from the surface of the tissue. When spraying TISSEEL, changes in blood pressure, pulse, oxygen saturation and end tidal CO₂ should be monitored because of the possibility of occurrence of air or gas embolism. When using the EASYSpray device, or an equivalent spray

device for open surgical procedures cleared by FDA, TISSEEL must not be sprayed in enclosed body areas and must be sprayed onto only visible application sites.

The sealer protein and thrombin solutions are denatured by alcohol, iodine or heavy metal ions. If any of these substances have been used to clean the wound area, the area must be thoroughly rinsed before the application of TISSEEL.

Apply TISSEEL as a thin layer as excess clot thickness may negatively interfere with wound healing.

5.3 Use in Surgery

Caution should be exercised to minimize the risk of intravascular application when using TISSEEL in surgery (see *Contraindications* (4.1) and *Adverse Reactions* (6.2)).

5.4 Use in Neurosurgical Procedures

The safety and effectiveness of TISSEEL used alone or in combination with biocompatible carriers in neurosurgical procedures or other surgeries involving confined spaces have not been evaluated, and its use in this setting is not approved by FDA (see *Adverse Reactions* (6.2) and *Drug Interactions* (7)).

5.5 Infection Risk from Human Plasma

TISSEEL is made from human plasma. Products made from human plasma may contain infectious agents, such as viruses, that can cause disease. The risk that such products will transmit an infectious agent has been reduced by screening plasma donors for prior exposure to certain viruses, by testing for the presence of certain virus infections, and by inactivating and removing certain viruses during the manufacturing process (see *Description* (11.1)). Despite these measures, such products can still potentially transmit disease. Because this product is made from human blood, it may carry a risk of transmitting infectious agents, e.g., viruses, and theoretically, the Creutzfeldt-Jakob disease (CJD) agent. This also applies to unknown or emerging viruses and other pathogens. The measures taken are considered effective for inactivation/removal of lipid enveloped viruses such as HIV, HBV, and HCV, and for the non-lipid enveloped virus such as HAV. These measures may be of limited value against small non-lipid enveloped viruses such as Parvovirus B19. Parvovirus B19 infection may be serious for pregnant women (fetal infection) and for individuals with immunodeficiency or increased red blood cell turnover (e.g., hemolytic anemia) (see *Patient Counseling Information* (17)). ALL infections thought by a physician possibly to have been transmitted by this product should be reported by the physician or other healthcare provider to Baxter Healthcare Corporation, telephone # 1-866-888-2472.

6 ADVERSE REACTIONS

Hypersensitivity or allergic/anaphylactoid reactions have occurred. In isolated cases, these reactions have progressed to severe anaphylaxis (see *Warnings and Precautions* (5.1)). No adverse events of this type were reported during clinical trials.

6.1 Clinical Trials Experience

Because clinical trials are conducted under widely varying conditions, adverse reaction rates observed in the clinical trials of a drug cannot be directly compared to rates in the clinical trials of another drug and may not reflect the rates observed in practice.

Increased D-Dimer levels have been observed during a clinical study in cardiovascular surgery (see *Clinical Studies* (14)), but did not exceed values reported in the literature occurring after this type of surgery. Postoperatively increased D-Dimers may result at least partly from the degradation of Fibrin Sealant.

There were no reports of serious, associated adverse reactions reported above 1% in clinical studies.

6.2 Post-Marketing Experience

Because adverse reactions are reported voluntarily and the population is of uncertain size, it is not always possible to reliably estimate the frequency of these reactions.

The following adverse reactions have been reported in the post-marketing experience.

IMMUNE SYSTEM DISORDERS: Hypersensitivity, including anaphylactic reactions and anaphylactic shock.

Anaphylactic reactions and anaphylactic shock have included fatal outcomes.

VASCULAR DISORDERS: hypotension, thromboembolism, including cerebral artery embolism, cerebral infarction*

SKIN AND SUBCUTANEOUS TISSUE DISORDERS: angioedema, erythema, impaired wound healing, pruritus, urticaria

CARDIAC DISORDERS: bradycardia, tachycardia

RESPIRATORY DISORDERS: bronchospasm, dyspnea, wheezing

GASTROINTESTINAL DISORDERS: nausea

GENERAL DISORDERS AND ADMINISTRATION SITE CONDITIONS: flushing, paresthesia

* as a result of intravascular application into the superior petrosal sinus

Class Effect: Air embolism has occurred with misapplication of fibrin sealant using the spray device. A post marketing fatality was reported in association with the use of another fibrin sealant when applied using a spray device. The case involved an attempt to stop active bleeding by applying the fibrin sealant using a spray device attached to a wall unit at a higher than recommended pressure for the spray device. In addition, the spray head was placed at a distance from the bleeding site that was closer than the recommended distance guidelines for the application of the sealant. The patient suffered a fatal air embolism.

Manifestations of hypersensitivity or allergic reactions associated with the class of fibrin sealant/hemostatic products include: application site irritation, chest discomfort, chills, headache, lethargy, restlessness and vomiting. There have been no reports of these reactions related to the specific use of TISSEEL.

There have been reports of serious adverse events such as paralysis and other compressive complications possibly related to the use of fibrin sealants in combination with resorbable hemostatic agents. There have also been reports of fatalities following the misadministration of topical thrombin (see *Warnings and Precautions* (5.4)).

7 DRUG INTERACTIONS

Oxidized cellulose-containing preparations may reduce the efficacy of TISSEEL and should not be used as carrier materials.

No interaction studies have been performed.

8 USE IN SPECIFIC POPULATIONS

8.1 Pregnancy

Pregnancy Category C

Animal reproduction studies have not been conducted with TISSEEL. It is also not known whether TISSEEL can cause fetal harm when administered to a pregnant woman or can affect reproduction capacity. Some viruses, such as parvovirus B19, are particularly difficult to remove or inactivate at this time. Parvovirus B19 most seriously affects pregnant women (fetal infection). TISSEEL should be given to a pregnant woman only if clearly needed.

8.3 Nursing Mothers

It is not known whether this drug is excreted in human milk. Because many drugs are excreted in human milk, caution should be exercised when TISSEEL is administered to nursing mothers.

8.4 Pediatric Use

Limited clinical study data are available with regard to the use of TISSEEL in children. Of 365 patients undergoing repeated cardiac surgery or emergency resection in a clinical trial of TISSEEL, 27 pediatric patients aged 16 years or younger were treated with TISSEEL. Of these, 2 patients were less than 6 months, 2 patients were between the ages of 6 months and 2 years, 15 patients were between 3–11 years of age, and 8 patients were between 12–16 years of age. There were no differences in safety observed between these subjects and the overall population (see *Clinical Studies* (14)).

8.5 Geriatric Use

Clinical studies included 218 patients aged 65 years of age or older treated with TISSEEL (159 undergoing cardiac surgery and 59 undergoing vascular surgery) (see *Clinical Studies* (14)). No overall differences in safety or effectiveness were observed between these subjects and younger subjects, and other reported clinical experience has not identified differences in responses between the elderly and younger patients, but greater sensitivity of some older individuals cannot be ruled out.

11 DESCRIPTION

TISSEEL [Fibrin Sealant] is a two-component fibrin sealant made from pooled human plasma. When combined, the two components, Sealer Protein and Thrombin mimic the final stage of the blood coagulation cascade.

Sealer Protein (Human)

Sealer Protein (Human) is a sterile, non-pyrogenic, vapor heated and solvent/detergent treated preparation made from pooled human plasma. Sealer Protein (Human) is provided either as a freeze-dried powder for reconstitution with Fibrinolysis Inhibitor Solution or as a finished frozen solution pre-filled into one side of a dual-chambered

TISSEEL (Fibrin Sealant)

syringe. The active ingredient in Sealer Protein (Human) is fibrinogen. Sealer Protein (Human) solution contains fibrinolysis inhibitor, synthetic Aprotinin, that delays fibrinolysis. Aprotinin (Synthetic) is manufactured by solid phase synthesis from materials completely of non-human/non-animal origin.

Thrombin (Human)

Thrombin (Human) is a sterile, non-pyrogenic, vapor heated and solvent/detergent treated preparation made from pooled human plasma. Thrombin (Human) is also provided either as a freeze-dried powder for reconstitution with Calcium Chloride Solution or as a finished frozen solution pre-filled into one side of a dual-chambered syringe.

The reconstituted solution or pre-filled syringe contains:

Sealer Protein Solution

Total protein: 96 – 125 mg/mL
 Fibrinogen: 67 – 106 mg/mL
 Aprotinin (Synthetic): 2250 – 3750 KIU/mL
 Other ingredients include: human albumin, tri-sodium citrate, histidine, niacinamide, polysorbate 80 and water for injection.

Thrombin Solution

Thrombin (Human): 400 – 625 units/mL*
 Calcium Chloride: 36 – 44 µmol/mL

Other ingredients include: human albumin, sodium chloride and water for injection.

* The potency expressed in units is determined with a clotting assay using an in-house internal standard that has been calibrated against the World Health Organization (WHO) Second International Standard for Thrombin, 01/580. Therefore, a unit (U) is equivalent to an International Unit (IU).

11.1 Viral Clearance

TISSEEL is made from pooled human plasma collected at US licensed collection centers. The vapor heat and solvent/detergent treatment steps used in the manufacturing process have been shown to be capable of significant viral reduction. No procedure, however, has been shown to be completely effective in removing viral infectivity from derivatives of human plasma (see *Warnings and Precautions (5.5)*). Validation studies were conducted using samples drawn from manufacturing intermediates for each of the two human plasma derived components. These samples were spiked with stock virus suspensions of known titers followed by further processing under conditions representative of respective manufacturing steps.

The virus reduction factors (expressed as log₁₀) of manufacturing steps for each of the viruses tested are shown in Table 5.

Table 5: Reduction Factors for Virus Removal and/or Inactivation

Sealer Protein Component					
Manufacturing Step	Mean Reduction Factors [log ₁₀] of Virus Tested				
	HIV-1	HAV	BVDV	PRV	MMV
Early Manufacturing Steps	n.d.	n.d.	n.d.	n.d.	2.7
Solvent/Detergent Treatment	>5.3	n.d.	>5.7	>5.9	n.d.
Vapor Heat Treatment	>5.5	>5.6	>5.7	>6.7	1.2
Overall Reduction Factor (ORF)	>10.8	>5.6	>11.4	>12.6	3.9
Thrombin Component					
Manufacturing Step	Mean Reduction Factors [log ₁₀] of Virus Tested				
	HIV-1	HAV	BVDV	PRV	MMV
Thrombin Precursor Mass Capture	3.2	1.5	1.8	2.5	1.2
Vapor Heat Treatment	>5.5	>4.9	>5.3	>6.7	1.0
Solvent/Detergent Treatment	>5.3	n.d.	>5.5	>6.4	n.d.
Ion Exchange Chromatography	n.d.	n.d.	n.d.	n.d.	3.6
Overall Reduction Factor (ORF)	>14.0	>6.4	>12.6	>15.6	5.8

n.d. = not determined

HIV-1: Human Immunodeficiency Virus 1; **HAV:** Hepatitis A Virus; **BVDV:** Bovine Viral Diarrhea Virus, a model for Hepatitis C Virus; **PRV:** Pseudorabies Virus, a model for lipid enveloped DNA viruses, among those is Hepatitis B Virus; **MMV:** Mouse Minute Virus, a model for B19V.

In addition, Human Parvovirus B19 (B19V) was used to investigate the upstream Thrombin precursor mass capture step, the Sealer Protein early manufacturing steps and the Thrombin and Sealer Protein vapor heating steps. Using quantitative PCR assays, the estimated B19V log reduction factors were: (a) 1.7 for the Thrombin precursor mass capture step, (b) 3.4 for Sealer Protein early manufacturing steps, (c) >4 for Thrombin vapor heat treatment and (d) 1.0 for Sealer Protein vapor heat treatment.

12 CLINICAL PHARMACOLOGY

12.1 Mechanism of Action

Upon mixing Sealer Protein (Human) and Thrombin (Human), soluble fibrinogen is transformed into fibrin, forming a rubber-like mass that adheres to the wound surface and achieves hemostasis and sealing or gluing of tissues. TISSEEL mimics the final coagulation cascade step as it has all relevant components to form a clot. TISSEEL is effective in heparinized patients and in patients medicated with anti-platelet drugs.

12.2 Pharmacodynamics

Thrombin is a highly specific protease that transforms the fibrinogen contained in Sealer Protein (Human) into fibrin. Fibrinolysis inhibitor, Aprotinin (Synthetic), is a polyvalent protease inhibitor that prevents premature degradation of fibrin. Preclinical studies with different fibrin sealant preparations simulating the fibrinolytic activity generated by extracorporeal circulation in patients during cardiovascular surgery have shown that incorporation of aprotinin in the product formulation increases resistance of the fibrin sealant clot to degradation in a fibrinolytic environment.

12.3 Pharmacokinetics

Unincorporated Aprotinin and its metabolites have a half-life of 30 to 60 minutes and are eliminated by the kidney. Pharmacokinetic studies were not conducted. TISSEEL is expected to be completely resorbed in 10 to 14 days.

Because TISSEEL is applied only topically, systemic exposure or distribution to other organs or tissues is not expected.

13 NONCLINICAL TOXICOLOGY

13.1 Carcinogenesis, Mutagenesis, Impairment of Fertility

Long-term animal studies to evaluate the carcinogenic potential of TISSEEL or studies to determine the effect of TISSEEL on fertility have not been performed.

14 CLINICAL STUDIES

14.1 Vascular Surgery

TISSEEL was evaluated in a prospective, controlled, randomized, single-blind, multicenter clinical study against manual compression with gauze pads in 140 subjects undergoing vascular surgery with expanded polytetrafluoroethylene (ePTFE) graft placement (arterio-arterial bypasses and AV shunts for dialysis access in the upper and lower extremity). Subjects received standardized dosages of heparin. Protamine was administered after the primary endpoint had been assessed. Long-term antiplatelet treatments were continued perioperatively at the surgeon's discretion.

Subjects were randomly assigned to TISSEEL or control when persistent bleeding at the study suture line was present after surgical hemostasis, i.e., sutures. Eligible bleedings before clamping and treatment application were defined as a minimum of 25% of the suture line bleeds or at least 5 suture line bleedings or any pulsatile or spurting needle hole bleeding. For the primary endpoint, hemostasis achieved at the study suture line at 4 minutes and maintained until surgical closure, a single application of TISSEEL was statistically significantly superior to control (p<0.0001; likelihood ratio chi-square test; 2.5% one sided) [ITT].

TISSEEL (Fibrin Sealant)

Table 6: Vascular Surgery

Hemostasis at the study suture line within 4 minutes and maintained until surgical closure		
	TISSEEL	Manual Compression
Intent to Treat Analysis	44/70 (62.9%)	22/70 (31.4%)

14.2 Cardiac Surgery

TISSEEL was evaluated in a prospective, parallel design, randomized (1:1), double-blind, multicenter clinical study against an earlier formulation of the product, TISSEEL VH, in 317 subjects undergoing cardiac surgery requiring cardiopulmonary bypass (CPB) and median sternotomy. Patients were treated with TISSEEL or the control product only when hemostasis was not achieved by conventional surgical methods. For the endpoint, hemostasis achieved at the primary treatment site within 5 minutes of treatment and maintained until closure of the surgical wound, TISSEEL was non-inferior to the earlier formulation of the product using a one-sided 97.5% confidence interval on the difference in the proportion of subjects successfully treated.

Table 7: Cardiac Surgery

Hemostasis within 5 minutes and maintained until surgical closure		
	TISSEEL	TISSEEL VH
Intent to Treat Analysis	127/144 (88.2%)	129/144 (89.6%)

14.3 Cardiac Reoperations

An earlier formulation of TISSEEL was evaluated in an open-label crossover study against control topical hemostatic agents in 489 patients undergoing cardiovascular reoperation or re-sternotomy at 11 institutions. Patients were randomized to TISSEEL or control hemostatic agents when a topical hemostatic was needed at the conclusion of surgery and after all attempts at surgical hemostasis. Patients were crossed to the alternative therapy if bleeding continued after the 5 minute endpoint. At 10 centers, TISSEEL was used after administration of protamine sulfate. At one site, TISSEEL could be used before administration of protamine sulfate. 365 of the 489 patients developed bleeding episodes requiring treatment. For the endpoint (successful hemostasis at 5 minutes), TISSEEL was statistically significantly superior to control topical hemostatic agents in these patients. Similarly, absolute time to cessation of bleeding was statistically significantly shorter for TISSEEL than for control topical hemostatic agents (p<0.0001, Gehan-Wilcoxon test, two sided).

Table 8: Cardiac Reoperations

Hemostasis within 5 minutes		
	TISSEEL	Control Topical Hemostatic Agent
	82.4% (159/193)	44.5% (76/172)
Pearson χ^2 two sided; p <0.0001; intent-to-treat analysis		

14.4 Splenectomy

In a single center, open label trial, an earlier formulation of TISSEEL was compared to historical controls in patients undergoing laparotomy for blunt or penetrating traumatic injury to the spleen and/or liver. Use of TISSEEL resulted in the need for statistically significantly fewer splenectomies than control hemostatic maneuvers (Refer to Table 9). TISSEEL did not result in significantly reduced mortality in patients with blunt or penetrating trauma to the liver alone or to the liver and spleen (p = 0.067, χ^2 , one sided).

Table 9: Splenectomy

Splenectomy Rate			
Injury to:	TISSEEL	Historic Controls	
Spleen	0/19	14/22	p <0.001
Spleen and liver	1/26	19/34	p <0.001

14.5 Colostomy Closure

In a single center, prospective open label study of 118 patients randomized to standard of care (58 patients) or standard of care plus fibrin sealant (60 patients) for elective colostomy closure after temporary colostomy placement for treatment of traumatic injury to the colon, the earlier version of TISSEEL plus standard of care was also shown to be significantly superior to standard of care alone (p = 0.0406, Jonckheere-Terpstra test for ordinal data, two sided) with regard to anastomotic complications (leakage, intra-abdominal abscess formation, re-operation, septic shock, and death).

16 HOW SUPPLIED/STORAGE AND HANDLING

How Supplied

TISSEEL is supplied in the following pack sizes and presentations:

Table 10: NDC Numbers

Pack Size	TISSEEL Kit (Freeze-Dried)	TISSEEL Kit (Freeze-Dried) with DUPLOJECT System	TISSEEL Pre-Filled Syringe (Frozen) with DUO Set
2 mL	0944-4201-03	0944-4201-04	0944-8402-02
4 mL	0944-4201-07	0944-4201-08	0944-8402-04
10 mL	0944-4201-11	0944-4201-12	0944-8402-10

TISSEEL Kit contains one vial each of:

- Sealer Protein Concentrate (Human), Vapor Heated, Solvent/Detergent Treated, Freeze-Dried, Sterile
- Fibrinolysis Inhibitor Solution, (Synthetic) Liquid, Sterile
- Thrombin (Human), Vapor Heated, Solvent/Detergent Treated, Freeze-Dried, Sterile
- Calcium Chloride Solution, Liquid, Sterile

TISSEEL Pre-Filled Dual-Chambered Syringe contains:

- Sealer Protein Solution, Vapor Heated, Solvent/Detergent Treated, Frozen Solution, Sterile
- Thrombin Solution, Vapor Heated, Solvent/Detergent Treated, Frozen Solution, Sterile
- Sterile accessory devices (DUO Set: 1 plunger, 2 joining pieces and 4 application cannulas)

Storage

TISSEEL Kit (Freeze-Dried)

Store at 2–25°C. Avoid freezing. Do not freeze or refrigerate reconstituted solutions.

TISSEEL Pre-filled Syringe (Frozen)

Store at –20°C. Do not refrigerate or re-freeze after thawing.

Do not use after the expiration date. Discard if packaging of any components is damaged.

17 PATIENT COUNSELING INFORMATION

Discuss the risks and benefits of this product with the patient since it is made from human plasma. Instruct patients to consult their physician if symptoms of B19 virus infection appear (fever, drowsiness, chills and runny nose) followed about two weeks later by a rash and joint pain (see *Use in Specific Populations (8.1)*).

Baxter Healthcare Corporation

Westlake Village, CA 91362 USA
 US License No. 140

This product is covered by US Patent No. 5,962,405.

Baxter, Duo, Duploject, Easyspray, Fibrinotherm and Tisseel are trademarks of Baxter International Inc.